

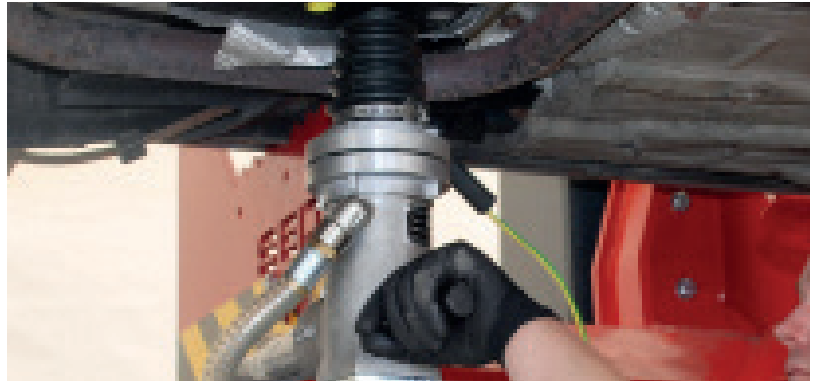

World leader in vehicle
de-pollution technology

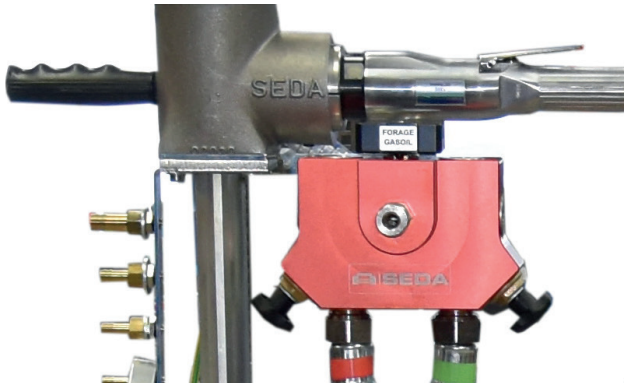

SEDA GreenPoint DUO

S-40300-V21

Fuel tank drilling device



The SEDA GreenPoint DUO is a version of the SEDA Tank Drilling Machine GreenPoint with an additional integrated fuel pump including inline filters and has a newly developed fuel switching system.

Your benefits:

- Clear fuel separation
- With integrated pump
- Autonomous use
- Easy to manoeuvre
- Fully air powered
- For plastic & steel tanks
- Powerful
- Higher fuel quality
- Explosion proof (ATEX)
- Fast and efficient working process
- **Quality proven (more than 30 million tanks depolluted accident free)**

When drilling into potentially explosive environments, performance is nothing without safety. The SEDA Tank Drilling Machine has been university tested and declared risk free and has passed the strict European ATEX certification test for machines, used in potentially explosive environments.

The reliable air powered drill and specially designed drill bit make light work of metal or plastic fuel tanks. While the powerful vacuum unit pulls the drilling head flush against the fuel tank, creating a seal, eliminating petrol fumes and allowing a fast and efficient drainage rate. The drilling process itself only takes a few seconds.

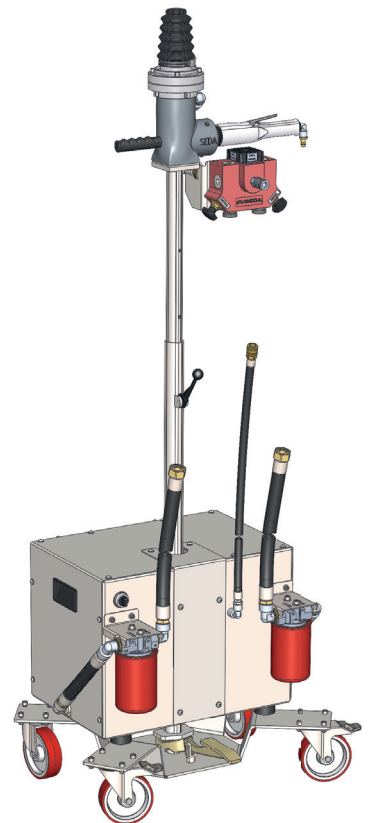

Newly developed fuel switching ►
(Petrol Diesel)



SEDA-Umwelttechnik GmbH

Schwendter Str. 10 / 6345 Kössen / Tirol / Österreich
UID-Nr.: ATU56621622 / FB-Nr.: FN 231790 v / FB-Gericht: Innsbruck
Certified company according to DIN EN ISO 9001

P: +43 5375 6318-0
F: +43 5375 6318-9
E: info@seda.at
W: www.seda-international.com



World leader in vehicle de-pollution technology



SEDA GreenPoint DUO

S-40300-V21



Tank Drilling Machine - V21-2

- Transparent hose to observe fuel flow
- 2 pumps for petrol and diesel
- 2-way valve
- # Drill petrol
- # Drill diesel



Tank Drilling Machine - V21-3

- Transparent hose to observe fuel flow
- 2 pumps for petrol and diesel
- 2-way valve
- # Suction petrol
- # Suction diesel
- # Drill petrol
- # Drill diesel



Removal via the FUEL IN-FLOW HOSE

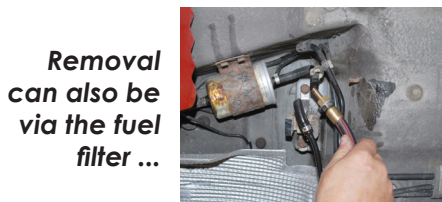

Removal can also be via the fuel filter ...

Fuel tank drilling device



The new version allows a further retraction of the Tank Drilling Machine to a minimum height of 160 cm. This makes maneuvering and placing the device underneath the vehicle much easier.

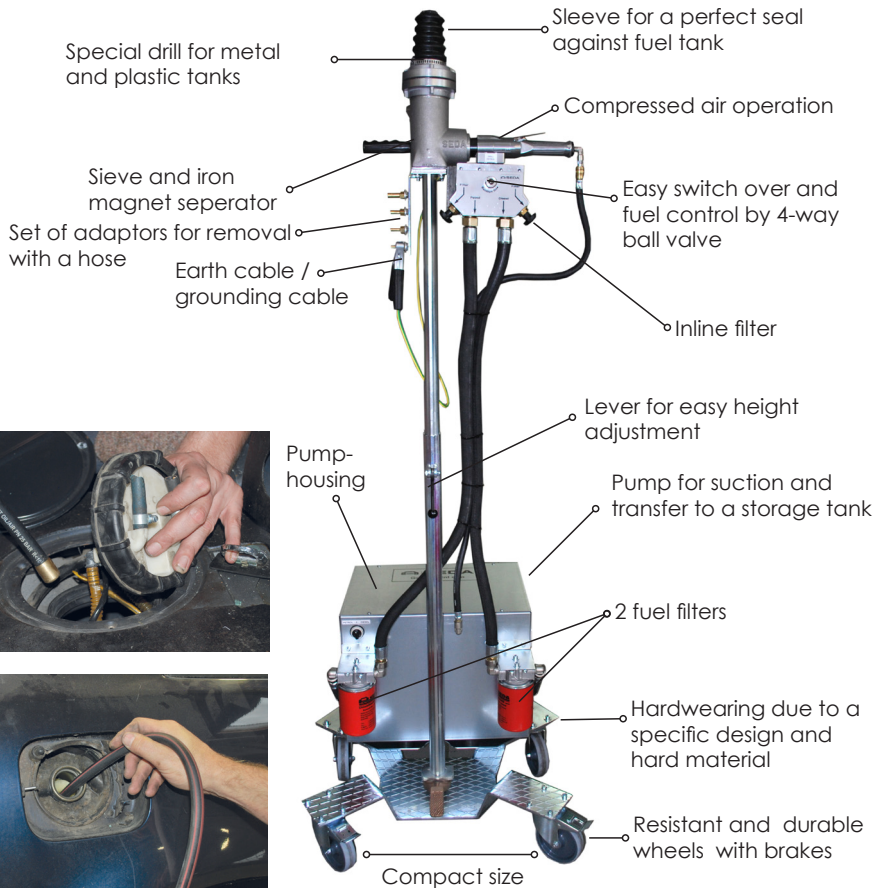

TECHNICAL DETAILS

Weight:	70 kg
Compressed air supply:	8 bar
Compressed air performance:	1.000 l/min
Special drill ø:	20 mm
Drill speed:	max. 220 U/min
Cutting speed:	max. 10,4 m/min

ORDER INFORMATION

- S-40300-V21-2** SEDA GreenPoint DUO fuel set (fuel switch))
- S-40300-V21-3** SEDA GreenPoint DUO fuel set (4-way valve)
- Alternative Device:**
- S-40200** SEDA GreenPoint fuel set

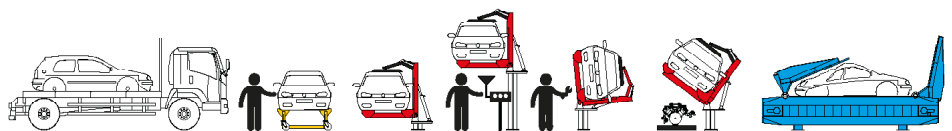

SEDA-Umwelttechnik GmbH

Schwendter Str. 10 / 6345 Kössen / Tirol / Österreich
 UID-Nr.: ATU56621622 / FB-Nr.: FN 231790 v / FB-Gericht: Innsbruck
 Certified company according to DIN EN ISO 9001

P: +43 5375 6318-0
F: +43 5375 6318-9
E: info@seda.at
W: www.seda-international.com